

BD
BK
BCIH

1345 ROW CLEANER

INSTALLATION INSTRUCTIONS

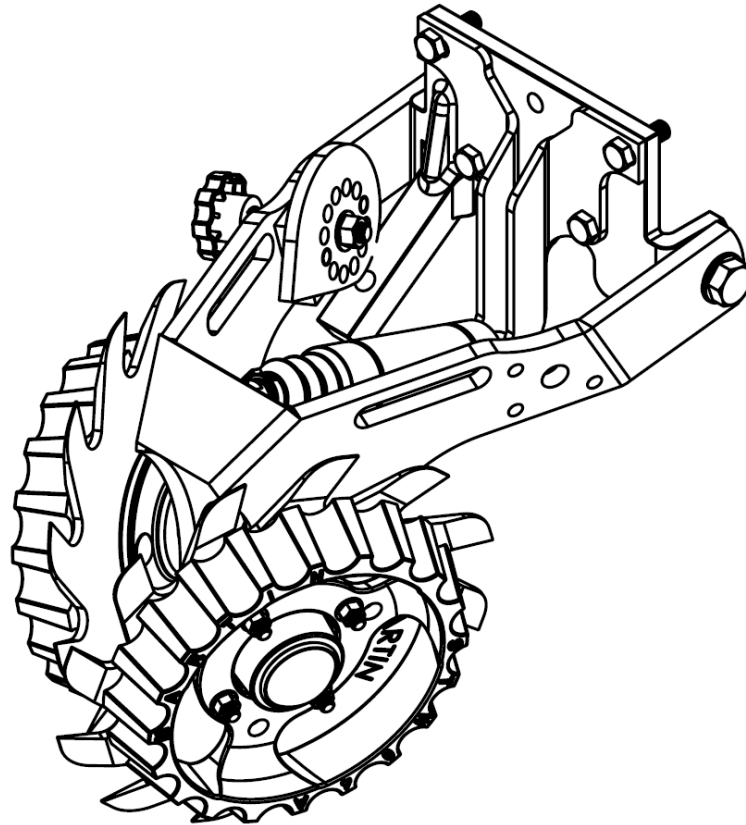

**SHOWN WITH BD MOUNT AND OPTIONAL SMARTCLEAN CYLINDER
AND BRACKETS, RAZOR WHEEL(RTW1412.5) , SIDE TREADER WHEELS
(STW-04) & CAM ADJUST (CA03-D)**



Martin Industries LLC

206 Elk Fork Road

Elkton, KY 42220

Telephone: 270-265-5817

E-Mail: martin@martintill.com

www.martintill.com



STEP 1 : ATTACH THE MOUNT TO THE PLANTER

Using four 1/2" X 1 1/2 " bolts, attach the mount to the planter face plate, and torque mounting nuts to 57 ft-lbs.

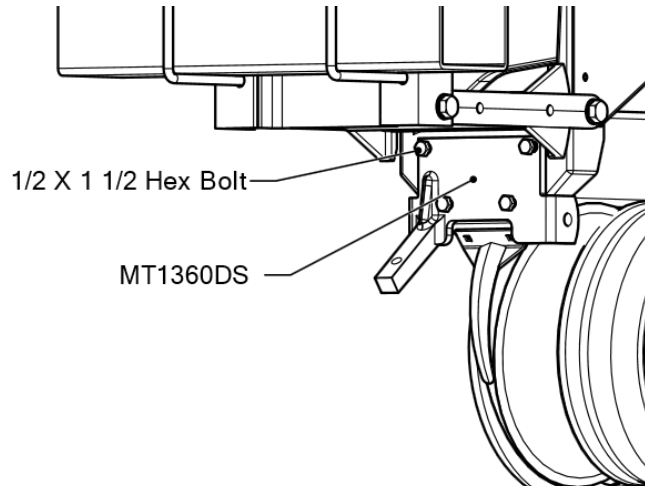

If you purchased the optional SmartClean System, Install the SmartClean cylinder top brackets on the mount (as shown in the picture) before attaching the mount to the planter. You have received 1/4" longer bolts in this case.

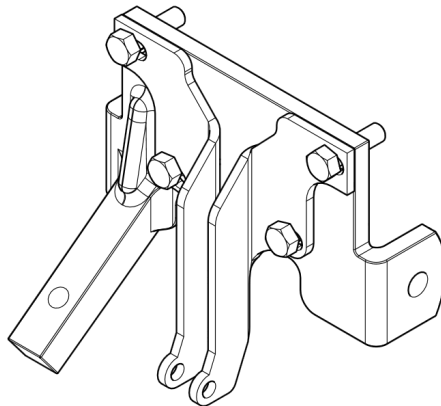

Some of the SmartClean bracket sets are shown below . Use the instructions in Step 4 to install the bottom brackets.

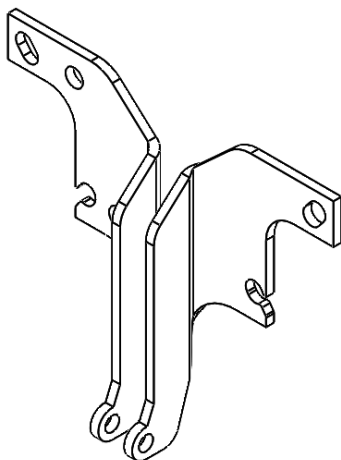

SC-BKW1345

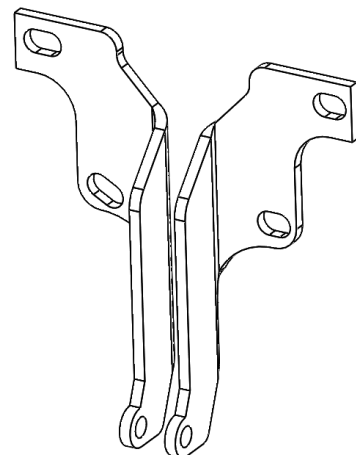

SC-BD1345

FOR CASEIH 1200 SERIES PLANTERS (BCIH 1360)

Attach the Right and Left L shape brackets (CIH1360R & CIH1360L) to the planter using provided two 1/2" X 3 1/2" Grade 8 bolts and nuts as shown in the right picture. Torque to 80 ft-lbs. Using four 1/2" X 1 1/2 " bolts, attach the mount to the L shape brackets, and torque mounting nuts to 57 ft-lbs.

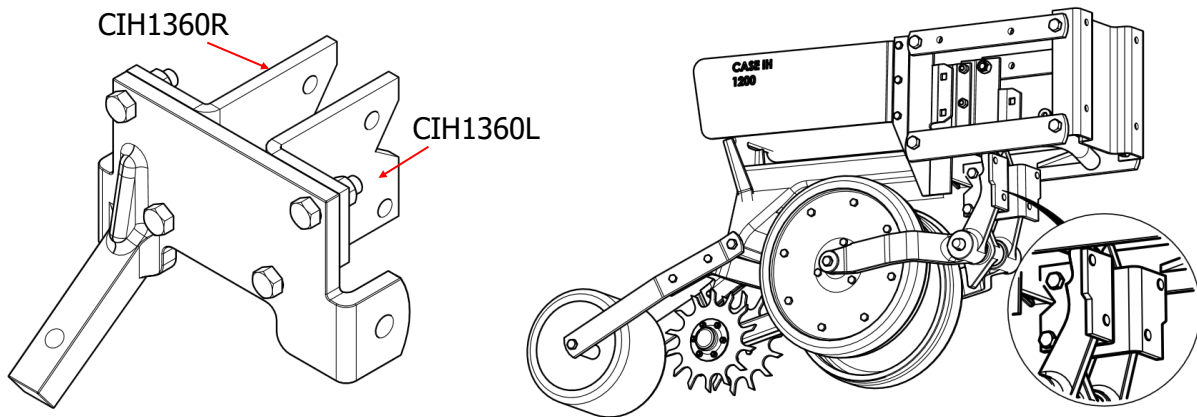

STEP 2: ATTACH 1360 FRAME ASSEMBLY TO THE MOUNT

1. Place the bushings (BU7858) inside the frame's arms pin point holes.
2. Align the holes in the mount and the frame assembly. Insert the 5/8" x 2" bolts and washers (you have not received washers if you are provided with flange bolts instead of HEX bolts) from the outside and place nuts on the 5/8" x 2" bolts from inside.
3. Tighten the bolts to 112 ft-lbs. Check after first day of use.
4. Check to ensure the frame is not binding on the mounting bracket and is free to float up and down.

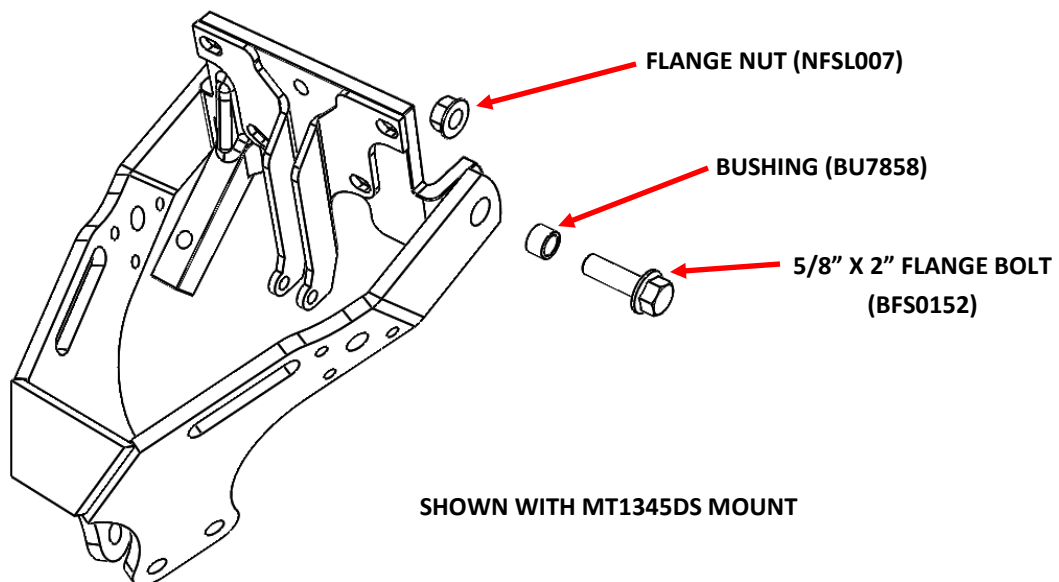

STEP 3 : INSTALL THREADED ADJUSTMENT ASSEMBLY

1. Place the adjustment assembly against the frame as shown in diagram below.
2. Secure the adjustment assembly to the frame using the three button head screws and nuts provided.
3. Put the 1/2" nut on the 1/2" x 4" bolt and thread the bolt into the tapped hole of the adjustment assembly. Use the 1/2" nut to lock the 4" adjustment bolt in place once the desired minimum depth setting has been determined.

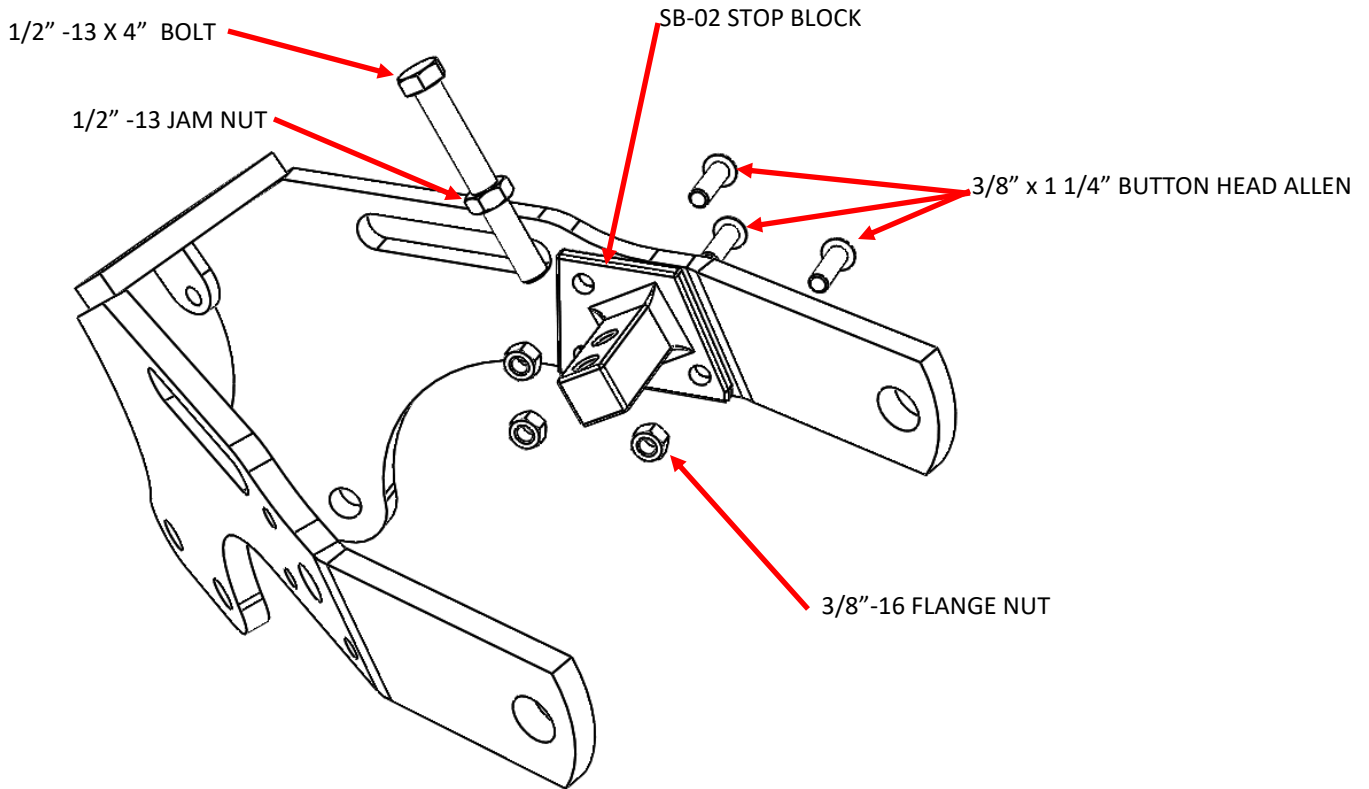

NOTE: IF USING THE CAM ADJUSTER OPTION SKIP THIS STEP AND PROCEED TO STEP 4

STEP 4 : INSTALL OPTIONAL CAM ADJUSTMENT ASSEMBLY

1. Mount the cam block to the frame using the three 3/8" button head bolts.
2. Slide the 1/2" x 4" bolt through the knob, spring, and support block and thread it into the cam.
3. Tighten the bolt until the cam is directly adjacent the support block but still loose enough to be disengaged from the pin by pushing on the knob.
4. Install the 1/2" nut on the end of the bolt and tighten securely against the cam. Torque to 57 ft-lbs.

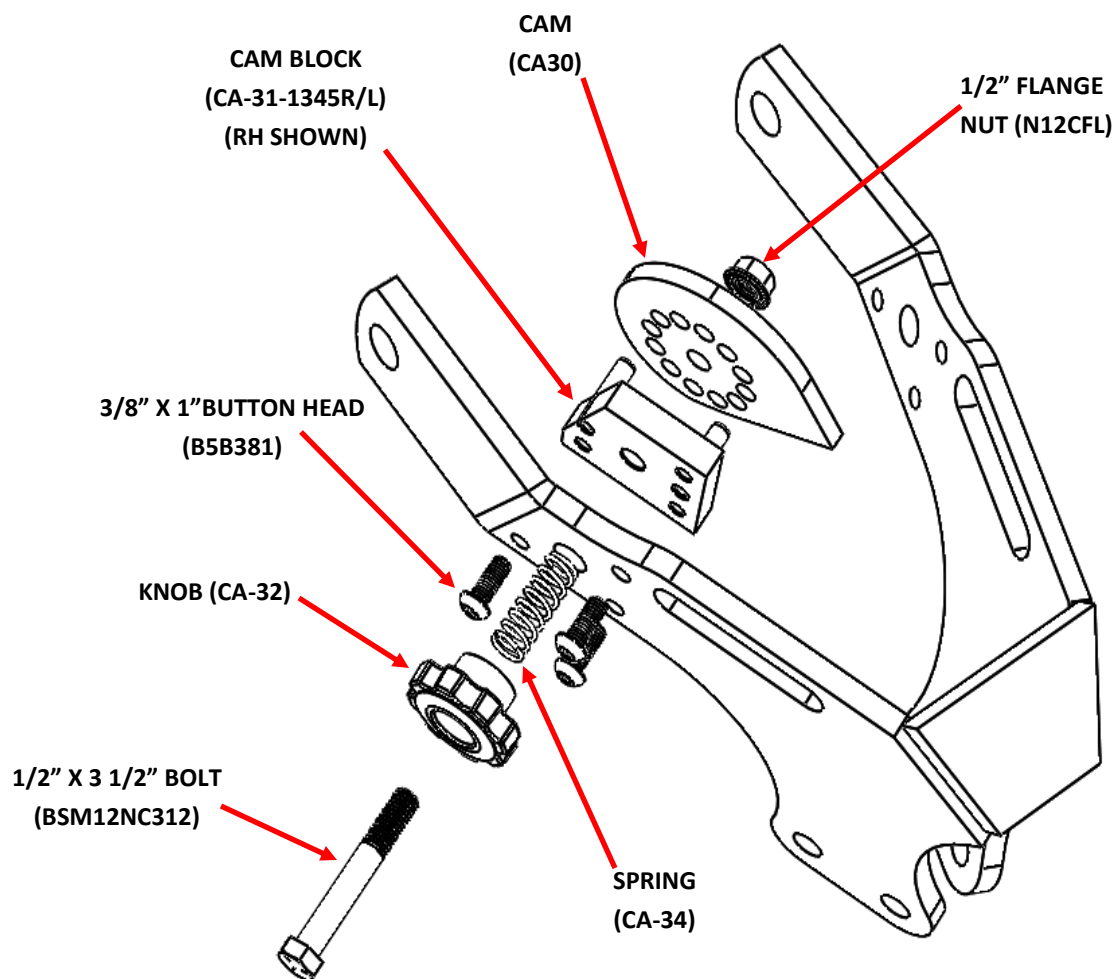

STEP 5 : DETERMINE THE BEST WHEEL CONFIGURATION FOR YOUR SOIL CONDITIONS

OPTION A: INTERSECTED

(Both wheels in front hole)

Both wheels forward provides maximum cleaning effect. The interlocked wheels till the middle of the seed row.

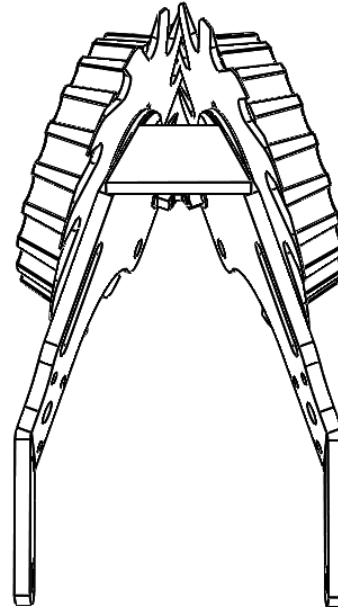
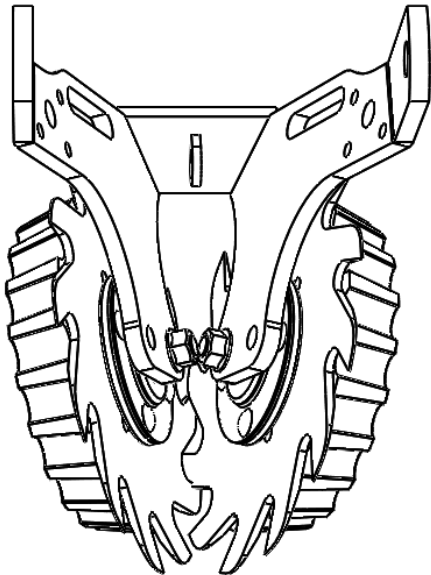

OPTION B: OFFSET

(Left wheel in front hole and right wheel in rear hole)

The staggered configuration allows the wheels to turn more easily in loose soil.

With this configuration, we suggest running the left wheels in the rear hole on the half of the planter and the right wheels in the rear hole on the other half of the planter (when viewed from behind).

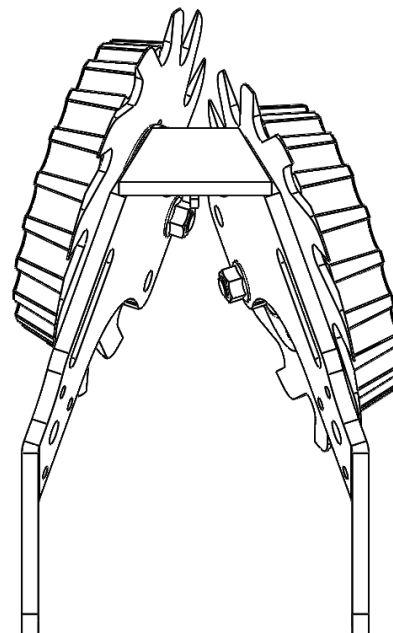
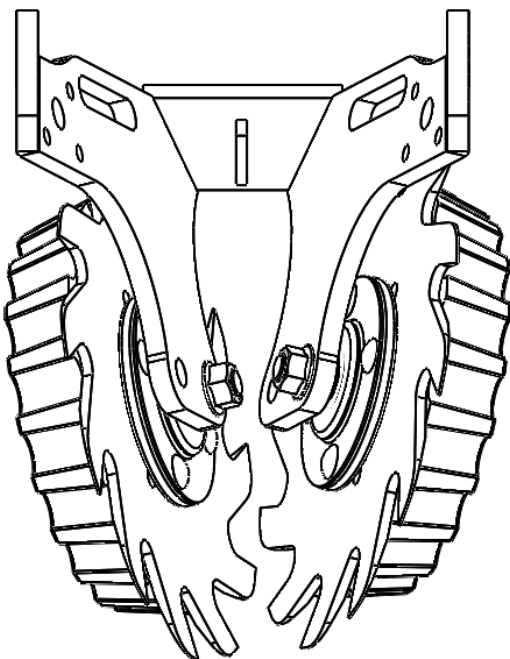

STEP 6: INSTALL WHEEL ASSEMBLIES

- 1) Secure the hub to the frame with the 5/8" X 3" flange bolt, washer and nut. Using a torque-wrench, tighten to 116 ft-lbs. Install the dust cap.
- 2) Install the wheel (part # to the outside) and side treader wheel on the hub, using the four carriage bolts and flange nuts. Torque to 23 ft-lbs. Re-tighten after first day's use.
- 3) The wheel marked TW3813-L4 is for use on the left side of the frame (as viewed from behind the machine). Repeat for opposite side.

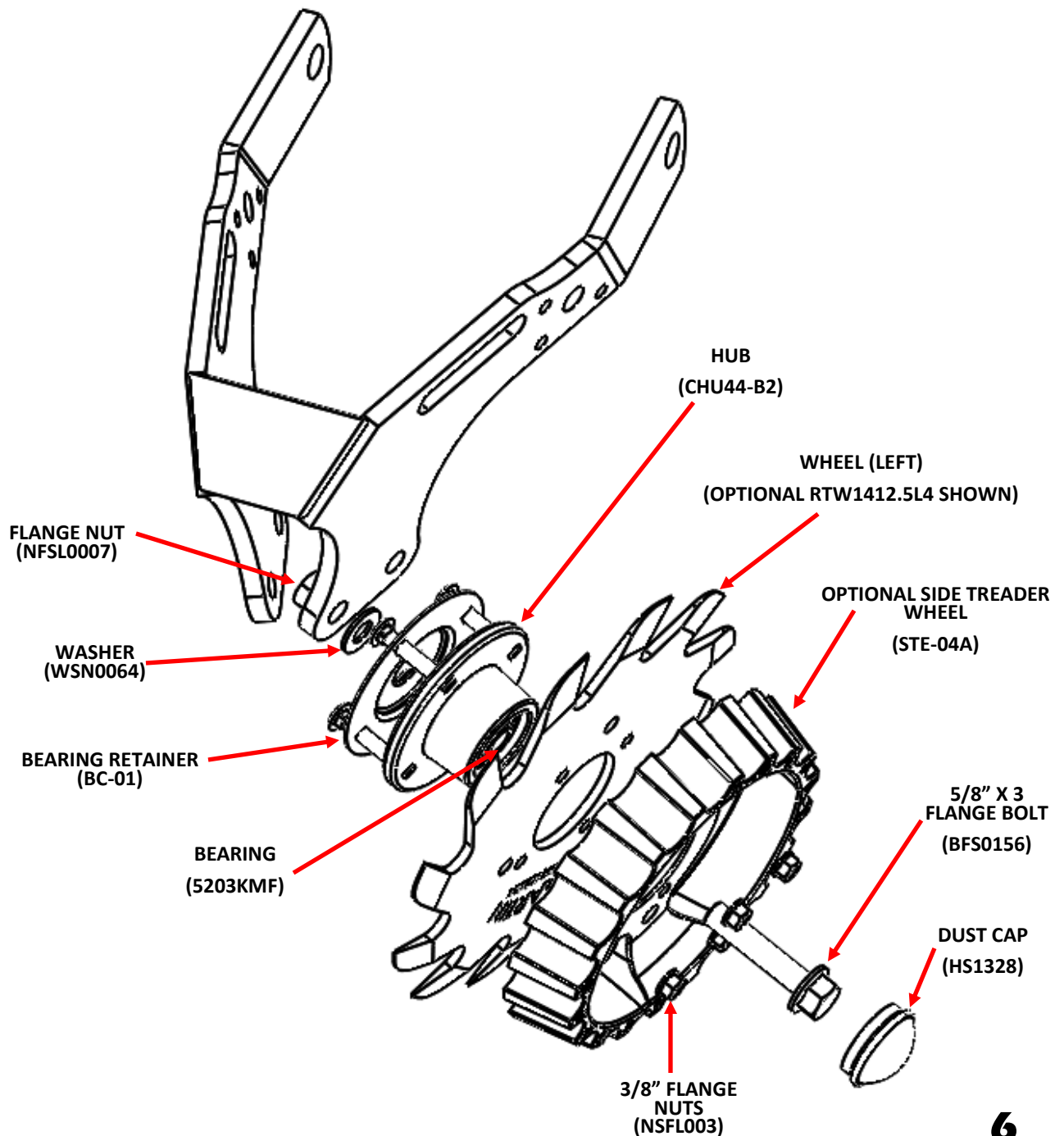

STEP 7: INSTALL OPTIONAL DEFLECTOR (SCRAPER)

NOTE: The Deflector (Scraper) is recommended when operating in wetter conditions, or damp stringy residue, to reduce wrapping.

NOTE: The Deflector (Scraper) comes in pair of left and right for left and right wheels.

Intersected Configuration (Wheel in front hole)

- 1) Place the deflector (Scraper) on the back of the assembled wheel unit (previously assembled in step 6) as shown here and pass the flange bolt (BFS0156) through the wheel assembly and the deflector and attach the flange nut (NFSL007) hand tighten and locate the deflector as shown and torque the flange bolt (BFS0156) to 116 ft-lbs being careful not to allow the deflector to rotate during bolt tightening.
- 2) The wheel marked TW3813-L4 (Or RTW1412.5-L4 for the Razor wheel) is for use on the left side of the frame (as viewed from behind the machine). Repeat for opposite side.

NOTE: When the deflector (scraper) is to be installed the washer (WSN0064) is NOT used

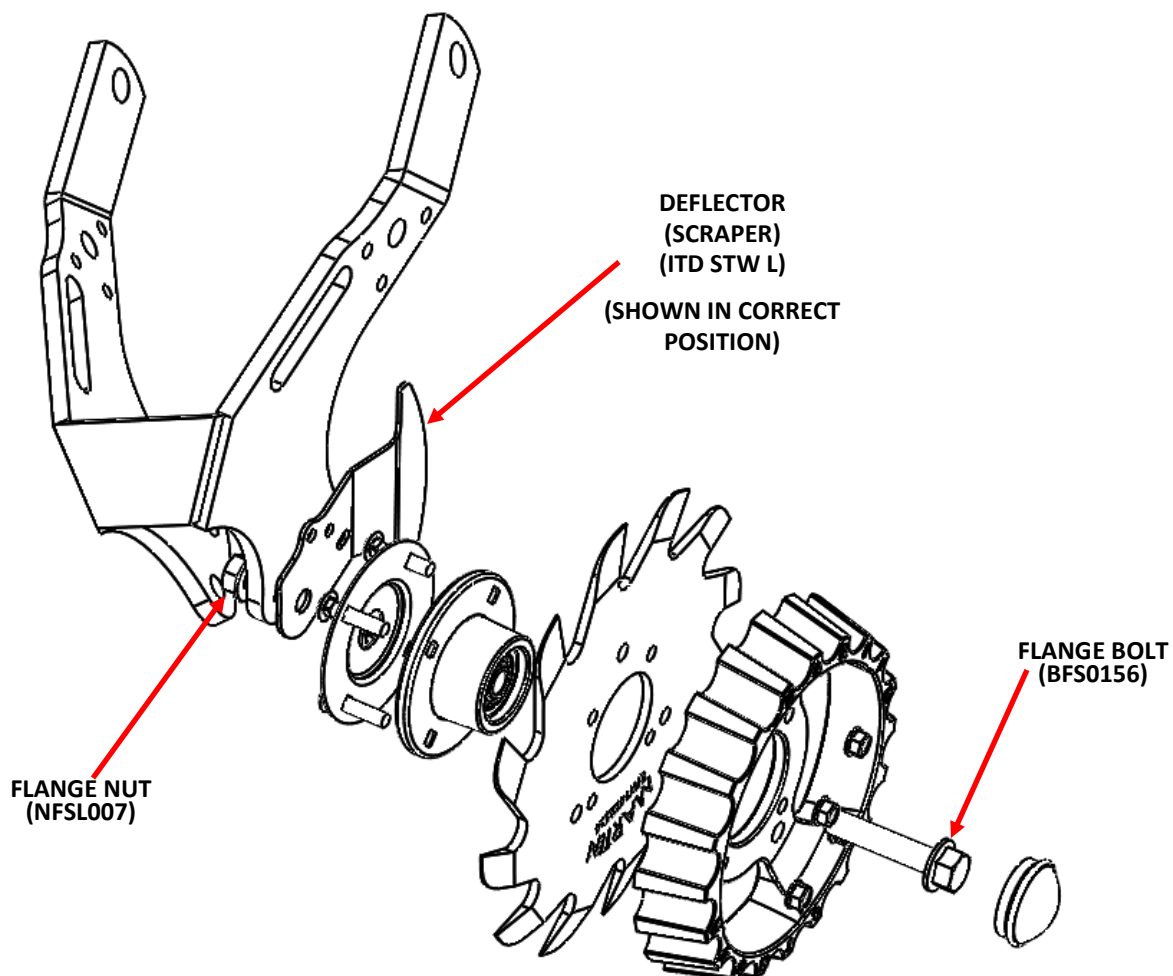

Offset Configuration (Wheel in rear hole)

- 1) Place the deflector (scraper) on the back of the assembled wheel unit (previously assembled in step 6) as shown here and pass the flange bolt (BFS0156) through the wheel assembly and the deflector using the rear hole in the frame unit and attach the flange nut (NFSL007) hand tighten and locate the deflector (scraper) as shown and torque the flange bolt (BFS0156) to 116 ft-lbs being careful not to allow the deflector to rotate during bolt tightening.
- 2) The wheel marked TW3813-L4 (Or RTW1412.5-L4 for the Razor wheel) is for use on the left side of the frame (as viewed from behind the machine). Repeat for opposite side.

NOTE: When the deflector (scraper) is used the washer (WSN0064) is NOT used

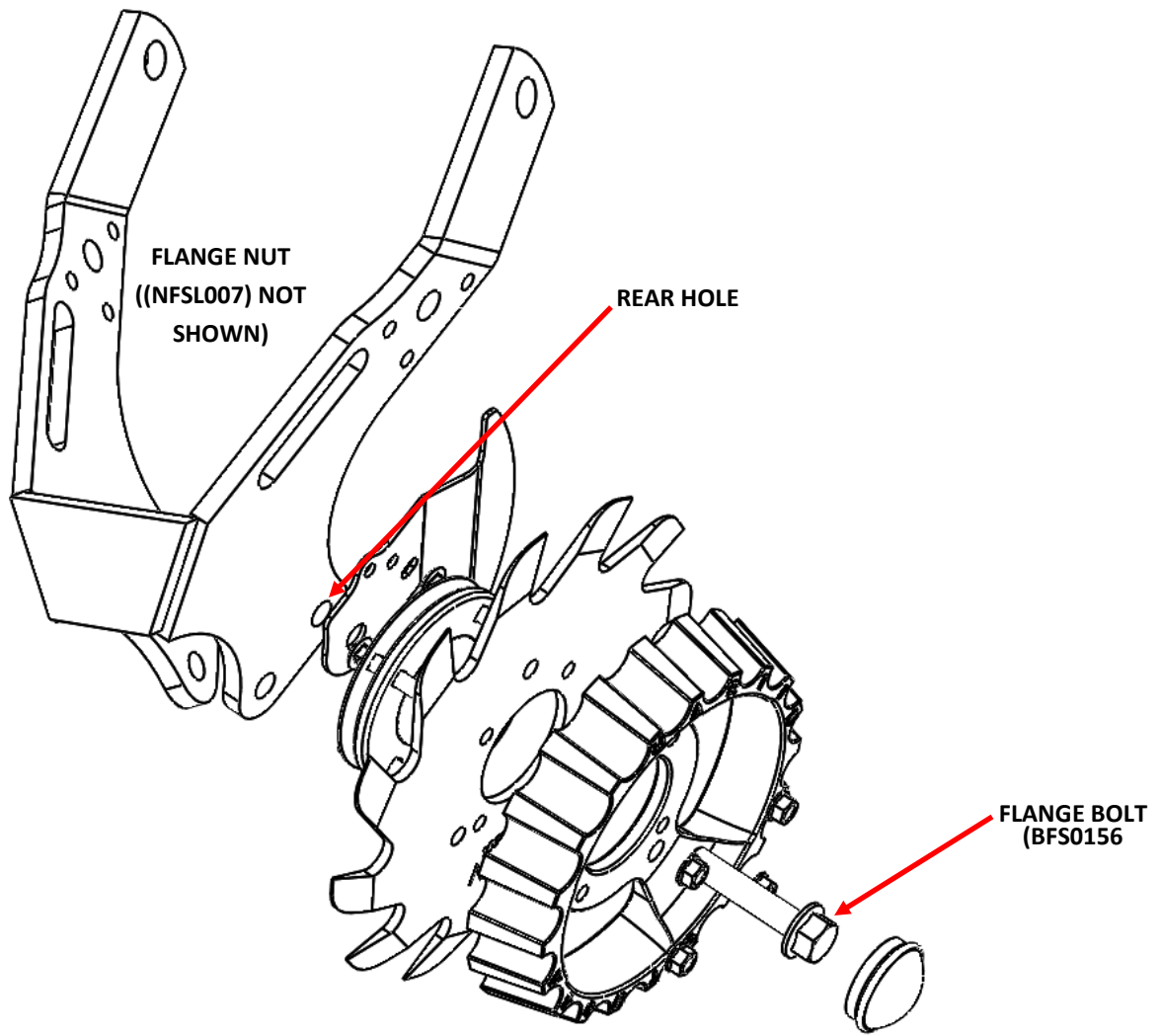

STEP 7 : INSTALL THE OPTIONAL SMARTCLEAN CYLINDER

Install the SmartClean cylinder between the top and bottom brackets. Use thicker (7/16 ") Pin on the top brackets and thinner (3/8") pin on the bottom bracket as shown in the picture below.

NOTE: Cylinder may be installed with elbow valves in either up or down orientation, depending on user preference.

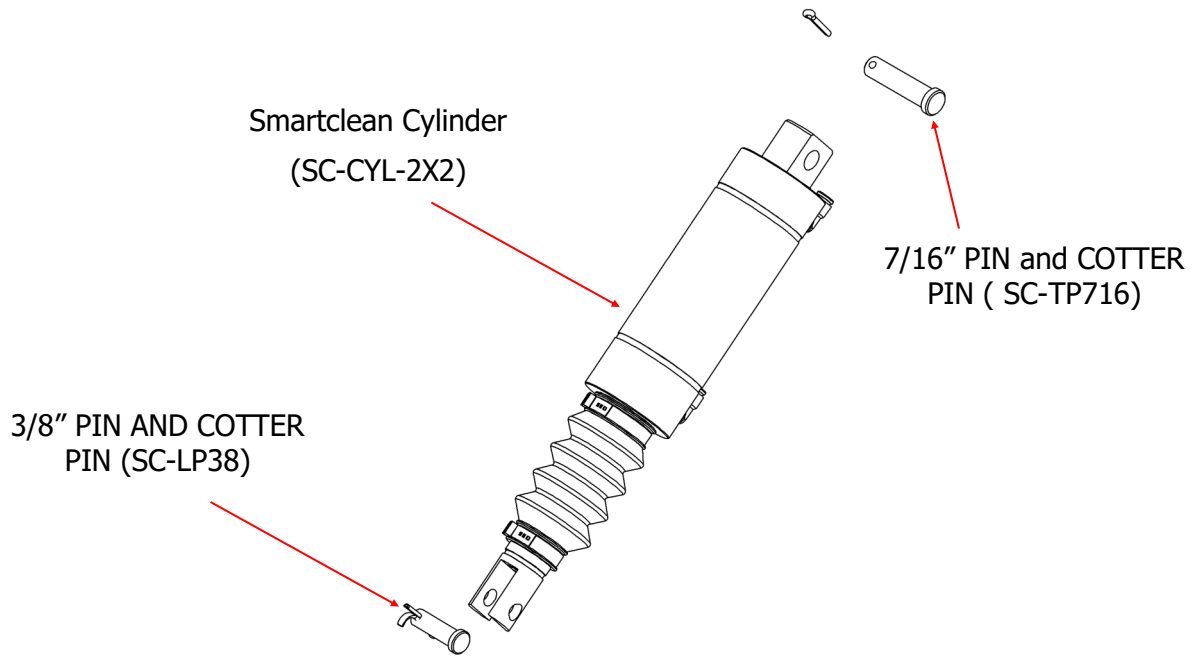

Note:

It is very important to limit the row cleaner down travel by threaded or cam adjustment assembly to prevent the air cylinder from extending fully by setting stop bolt or cam to catch the row cleaner just before the cylinder reaches the end of its stroke. Failure to do so will destroy the cylinder prematurely.

PARTS LIST FOR 1345 HUB ASSEMBLY (CHU44-B2)

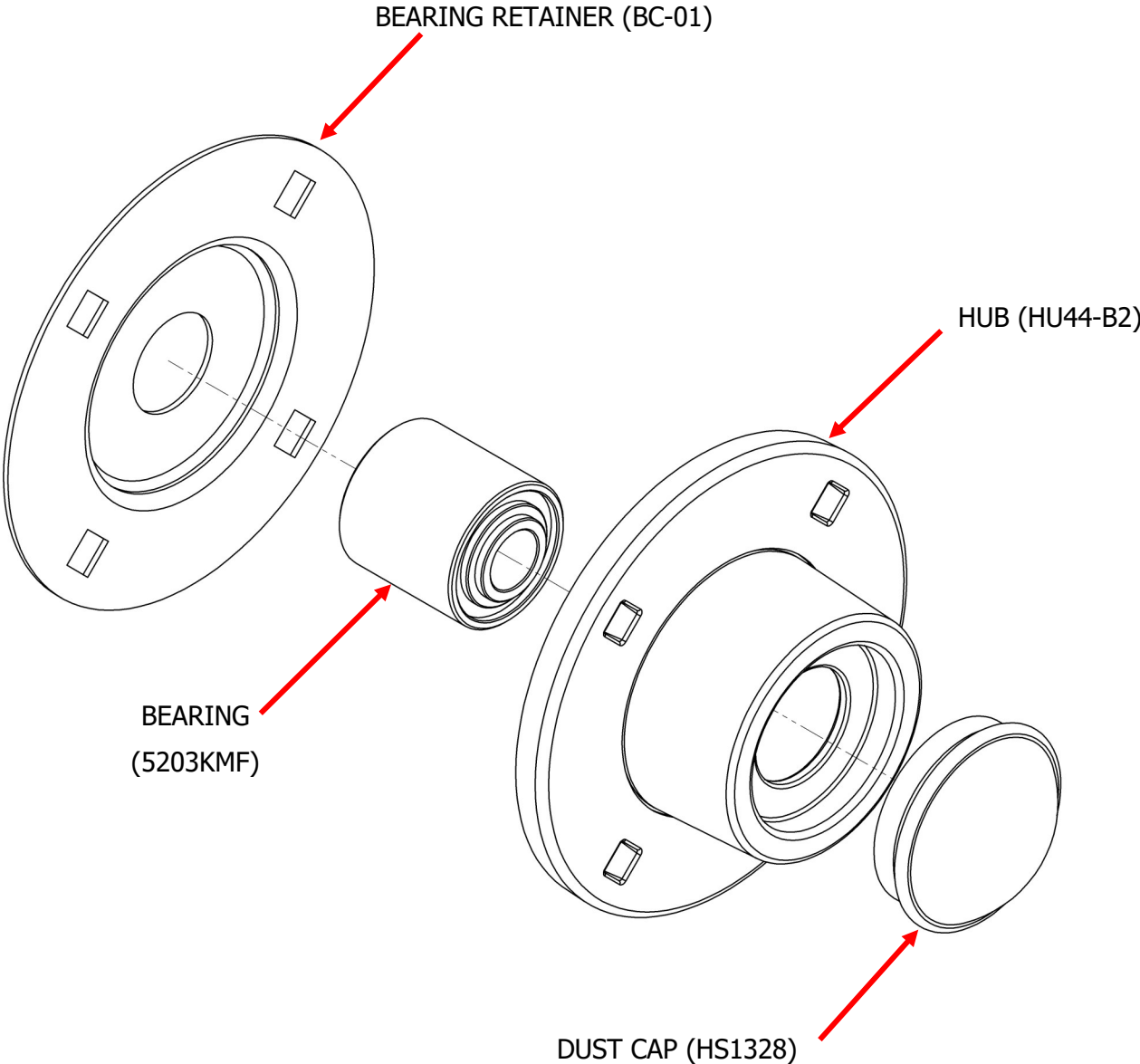



The most trusted name in no-till
Established 1991

Martin Industries LLC

206 Elk Fork Road

Elkton, KY 42220

Telephone: 270-265-5817

E-Mail: martin@martintill.com