

BSCW1344

**Spading Closing Wheel for 1700 Deere and Kinze
planters with bolt on hubs
Installation Instructions**

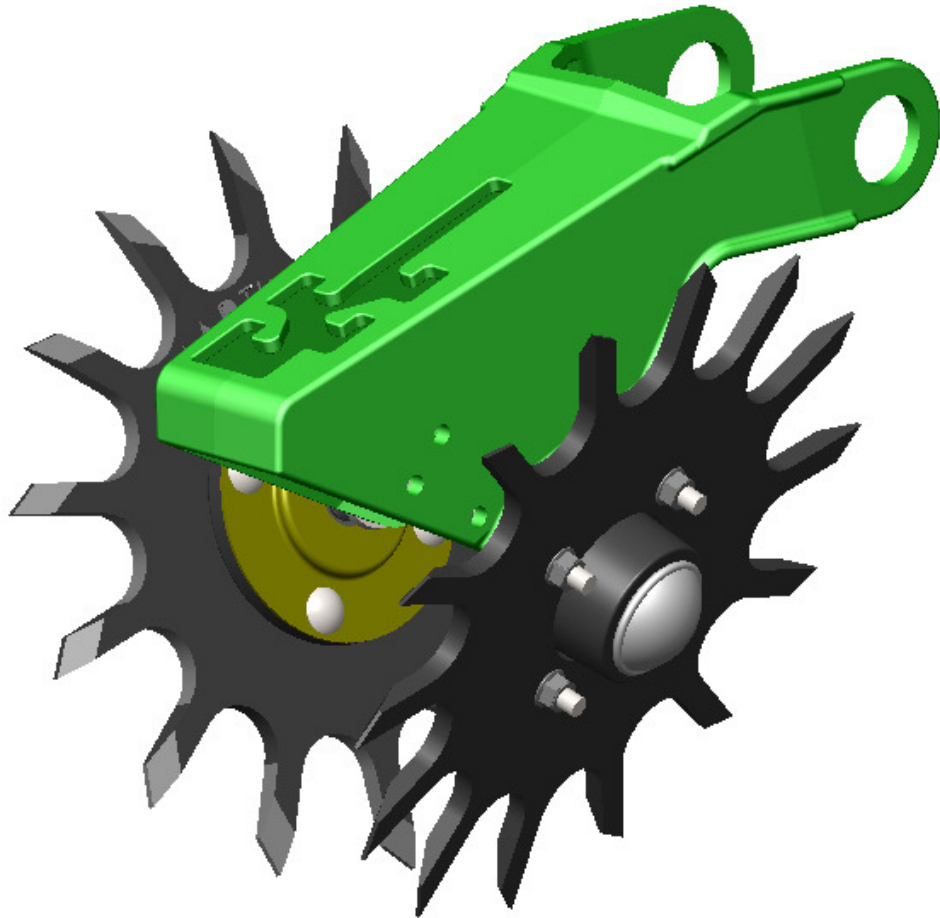

Martin Planter Attachments

Martin Industries LLC

206 Elk Fork Road

Elkton, KY 42220

Telephone: 270-265-5817

E-Mail: martin@martintill.com

www.martintill.com



BSCW1344 ASSEMBLY INSTRUCTIONS.

- 1) Attach the spade wheel on to the CHU44-B2 hub, with part number facing the hub.
- 2) Place the BC-01 bearing cap on the opposite side of the CHU44-B2 hub.
- 3) Insert the four 3/8" X 1 1/4" carriage bolts then add the four 3/8" flange nuts. Tighten.
- 4) Use spacer and washer for recommended spacing.
- 5) Repeat the assembly instructions for the opposite side assembly.

(IMPORTANT NOTE: The TW3813-L4 will mount on the RIGHT SIDE and the TW3813-R4 will mount on the LEFT SIDE. The Part Number on the wheels will be facing the furrow.)

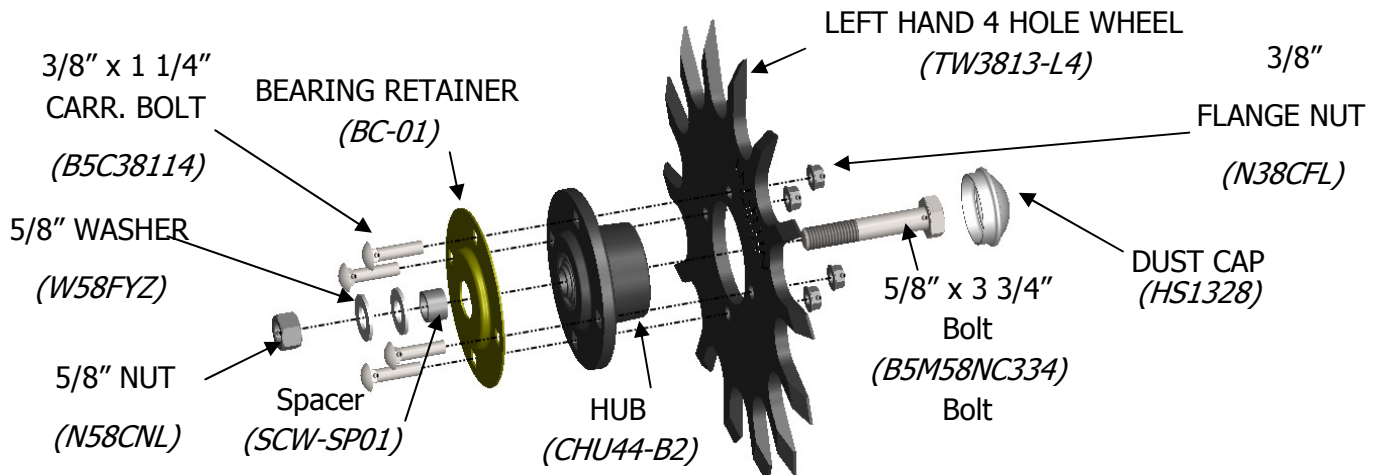

INSTALLING THE BSCW1344 TO THE TAIL WHEEL HOUSING

- 1) Insert the 5/8" x 3 3/4" bolt thru the hole in the tail wheel housing then add the nut and tighten. Repeat for opposite side
- 2) Recommended distance is 2 1/2" as shown below.

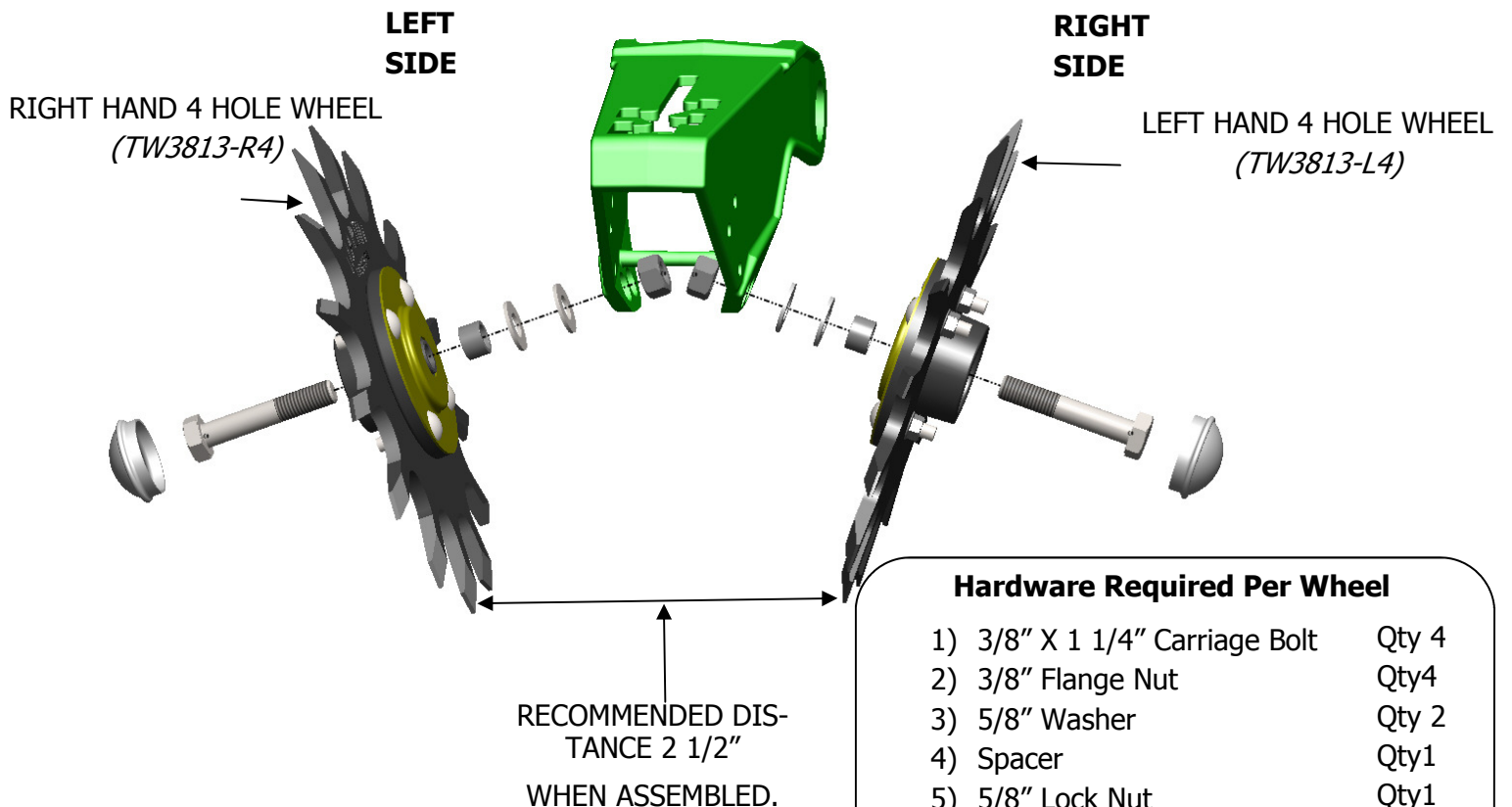

Hardware Required Per Wheel

- | | |
|--------------------------------|-------|
| 1) 3/8" X 1 1/4" Carriage Bolt | Qty 4 |
| 2) 3/8" Flange Nut | Qty4 |
| 3) 5/8" Washer | Qty 2 |
| 4) Spacer | Qty1 |
| 5) 5/8" Lock Nut | Qty1 |
| 6) 5/8" X 3 3/4" Bolt | Qty1 |