

BSCW1344D

**Dimple Closing Wheel for 1700 Deere and Kinze
planters with bolt on hubs**

Installation Instructions

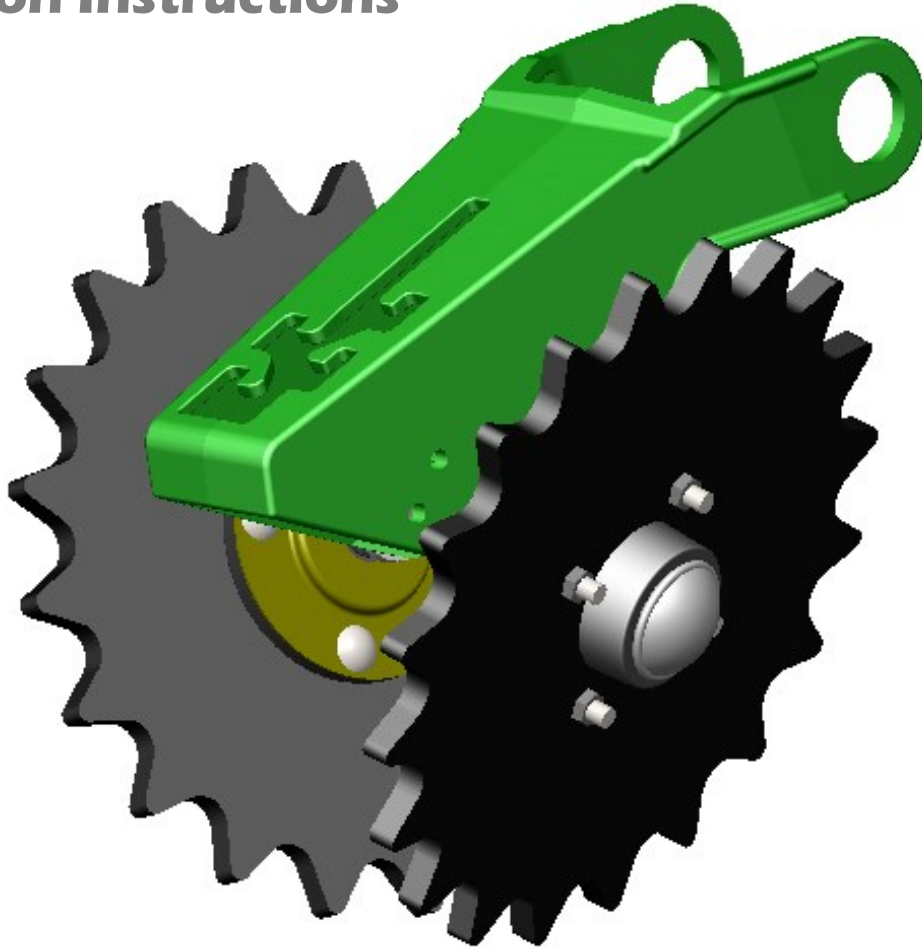

Martin Planter Attachments

Martin Industries LLC

206 Elk Fork Road

Elkton, KY 42220

Telephone: 270-265-5817

E-Mail: martin@martintill.com

www.martintill.com



BSCW1344D ASSEMBLY INSTRUCTIONS

- 1) Place the DW2013-4 onto the CHU44-B2. Place the BC-01 against the opposite side of the CHU44-B2. Align the four holes with each other.
- 2) Insert the four 3/8" x 1 1/4" carriage bolts through the holes. Add the four 3/8" flange nuts and tighten.
- 3) Insert the 5/8" x 3 3/4" bolt through the center hole. Add the spacer then add washers as needed.

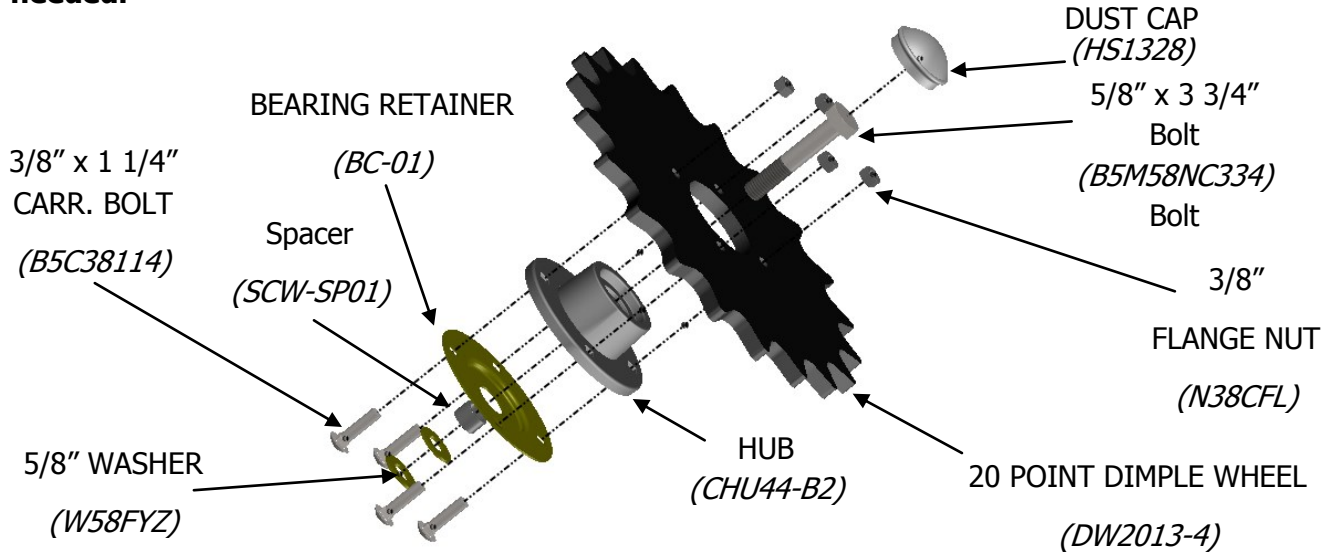

INSTALLING THE BSCW1344D TO THE TAIL WHEEL

- 1) Insert the bolt through the hole in tail wheel (Add or take off the 5/8" washers as needed for preferred spacing), then add the 5/8" nut and tighten. Install HS1328 dust cap.
- 2) Repeat step 1 for opposite side.

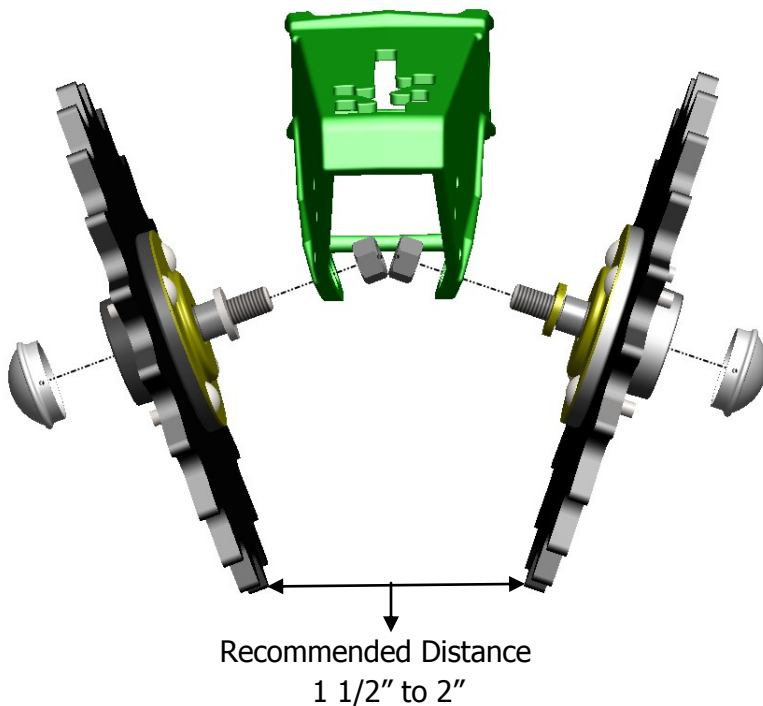

Hardware Required Per Wheel

1) 3/8" X 1 1/4" Carriage Bolt	Qty 4
2) 3/8" Flange Nut	Qty 4
3) 5/8" Washer	Qty 5
4) Spacer	Qty 1
5) 5/8" Lock Nut	Qty 1
6) 5/8" X 3 3/4" Bolt	Qty 1
7) HS1328	Qty 1
8) BC-01	Qty 1