

# **BSCW1444C**

**Cupped Razor Closing Wheel for 1700 Deere and  
Kinze planters with bolt on hubs  
Installation Instructions**

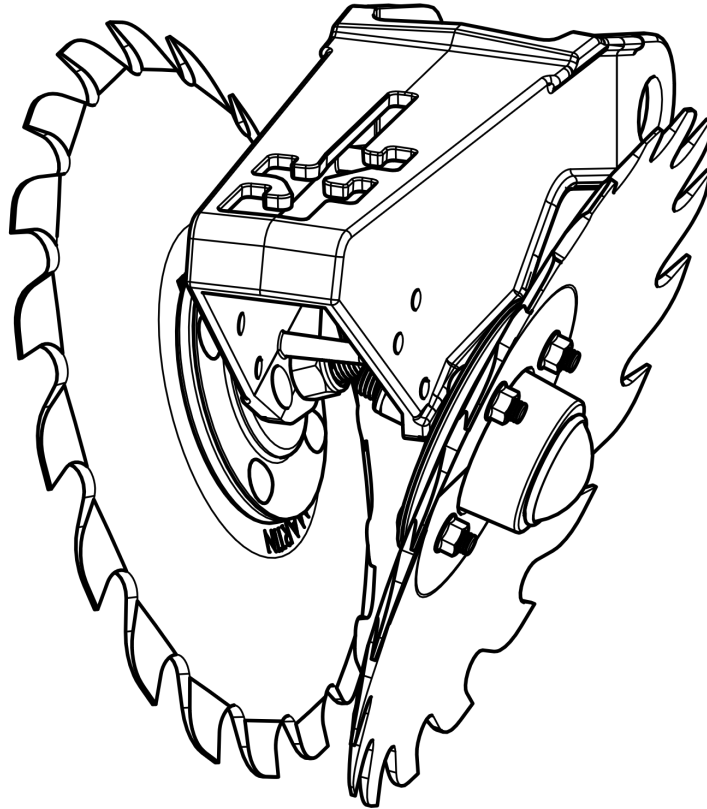

## **Martin Planter Attachments**

**Martin Industries LLC**

206 Elk Fork Road

Elkton, KY 42220

Telephone: 270-265-5817

E-Mail: [martin@martintill.com](mailto:martin@martintill.com)

[www.martintill.com](http://www.martintill.com)



**BSCW1444C ASSEMBLY INSTRUCTIONS.**

- 1) Attach the spade wheel on to the CHU44-B2 hub, with part number facing the hub.
- 2) Place the BC-01 bearing cap on the opposite side of the CHU44-B2 hub.
- 3) Insert the four 3/8" X 1 1/4" carriage bolts then add the four 3/8" flange nuts. Tighten.
- 4) Use 1 washer per wheel for recommended start spacing. If different spacing is desired, add included extra washers between the hub and housing.
- 5) Torque 3/8 bolts to 23 ft-lbs. Re-tighten after first day's use.
- 6) Repeat the assembly instructions for the opposite side assembly.

**(IMPORTANT NOTE: The RTW141418RC will mount on the LEFT SIDE and the RTW141418LC will mount on the RIGHT SIDE. The Part Number on the wheels will be facing the furrow.)**

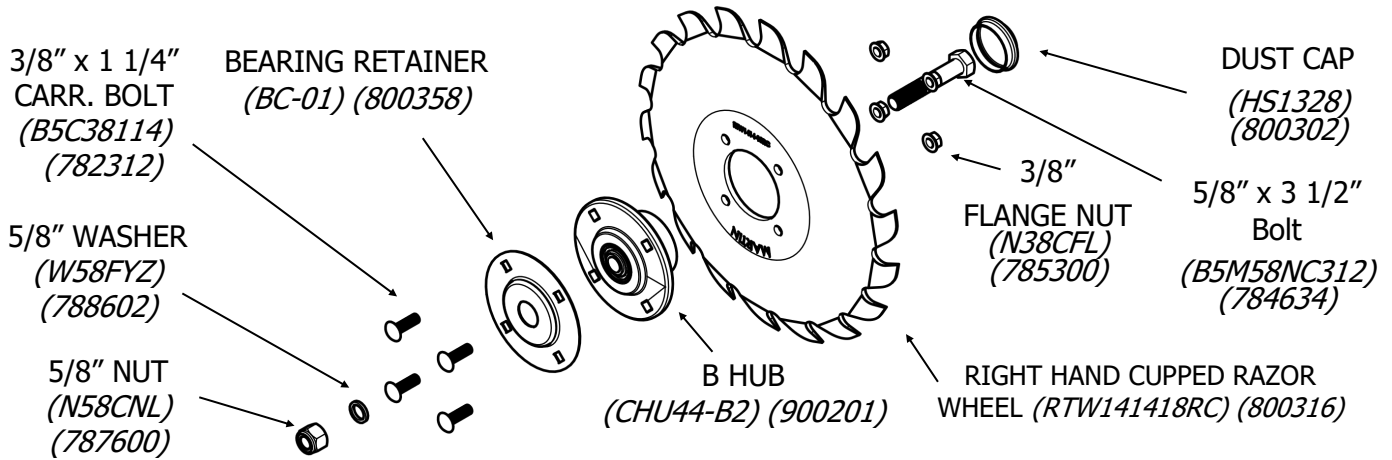

**INSTALLING THE BSCW1444C TO THE TAIL WHEEL HOUSING**

- 1) Insert the 5/8" x 3 1/2" bolt thru the hole in the tail wheel housing then add the nut and tighten. Repeat for opposite side
- 2) Recommended distance is 2 3/4" as shown below.

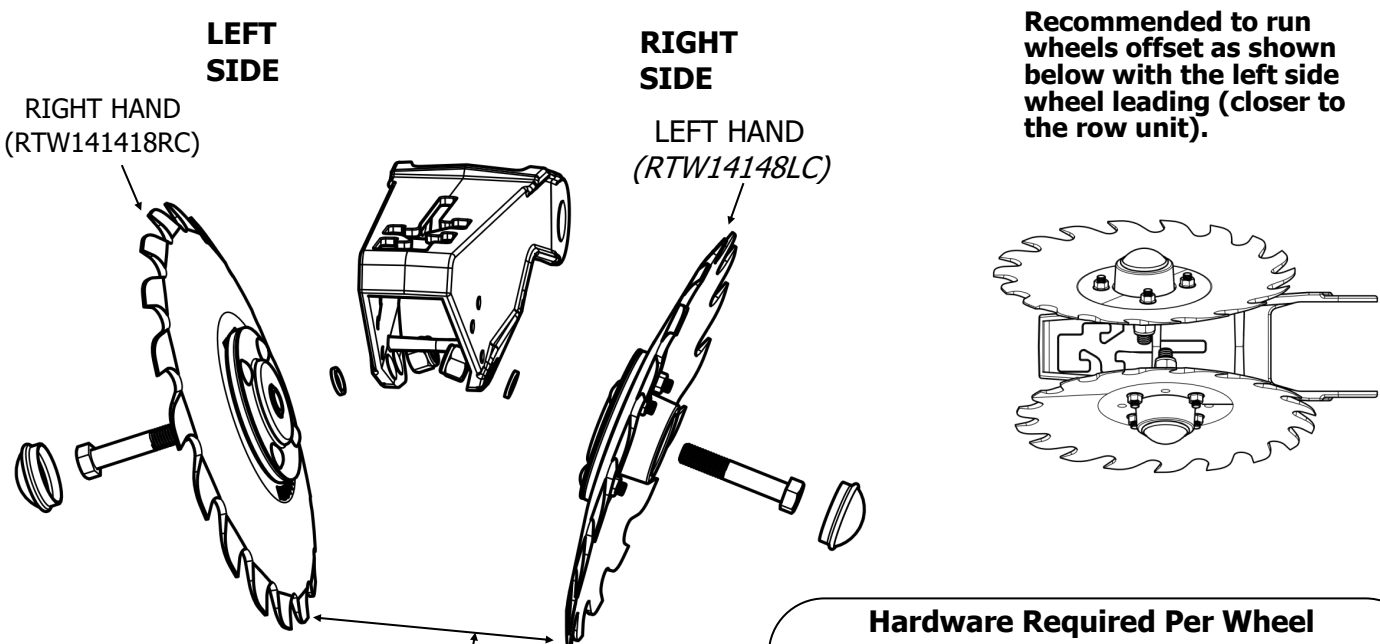

RECOMMENDED STARTING DISTANCE 2 3/4" WHEN ASSEMBLED.

| Hardware Required Per Wheel    |       |
|--------------------------------|-------|
| 1) 3/8" X 1 1/4" Carriage Bolt | Qty 4 |
| 2) 3/8" Flange Nut             | Qty 4 |
| 3) 5/8" Washer                 | Qty 3 |
| 4) 5/8" Nylock Nut             | Qty 1 |
| 5) 5/8" X 3 1/2" Bolt          | Qty 1 |