

BSCW1541

**Spading Closing Wheel for Deere 7000 and early
Kinze planters with roll pin style hubs**

Installation Instructions

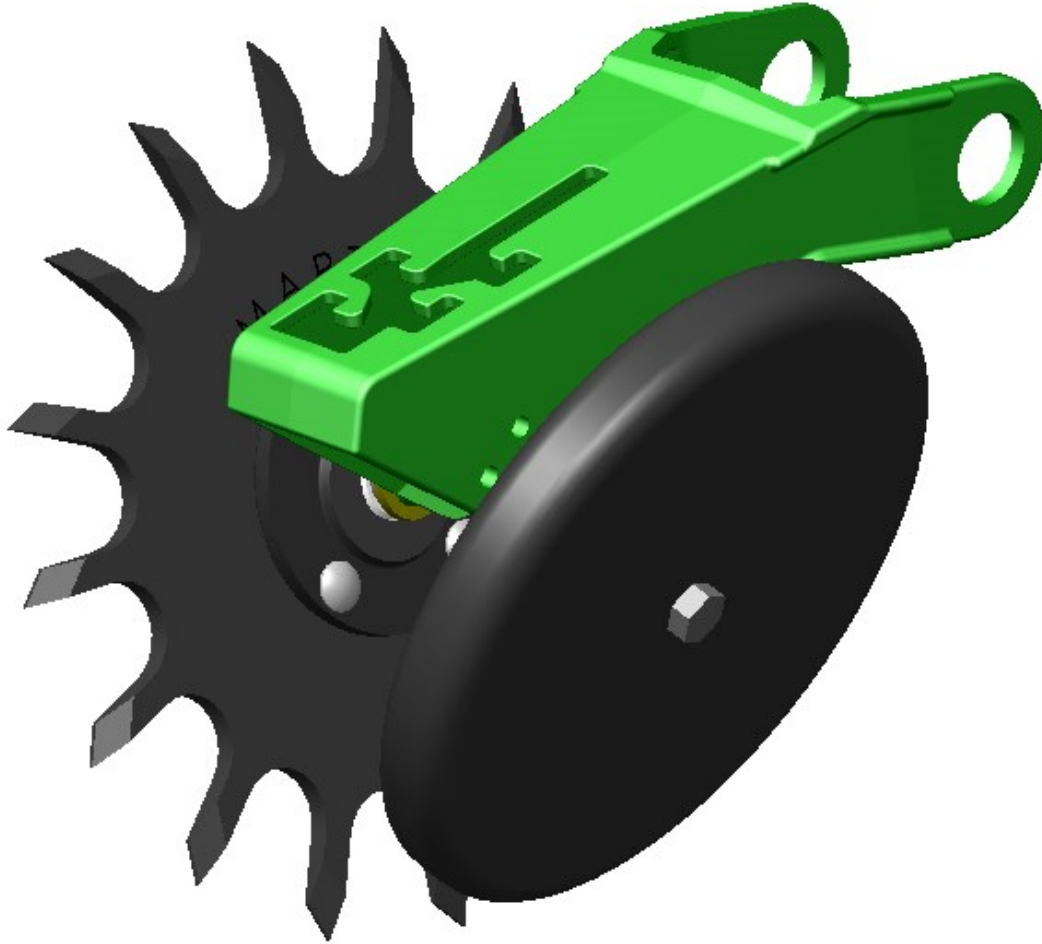

Martin Planter Attachments

Martin Industries LLC

206 Elk Fork Road

Elkton, KY 42220

Telephone: 270-265-5817

E-Mail: martin@martintill.com

www.martintill.com



- 1) Attach the spade wheel to the CHU44-A Hub with the 3/8" x 1 1/4" Carriage Bolts and 3/8" Flange Nuts. The bolts should be inserted through the hub first, then through the wheel, with the part number on the wheel facing the hub.
- 2) Remove the smooth closing wheel with bearing from the planter.
- 3) Attach adapter axle to the closing wheel arm using the existing roll pin.
- 4) Place as many 5/8" flat washers as needed for the correct spacing on adapter axle.
- 5) Install replacement hub on the axle, with part number on wheel facing furrow. Do not place any flat washers on hub side that is away from furrow.
- 6) After achieving the correct spacing, secure hub with 5/8" Nyloc Nut and install Dust Cap.

Note:

Wheel with part number ending with R4 should be installed on the Left side with part number facing the furrow. Repeat for right side using wheel with part number ending with L4. This applies to all closing wheels and is the opposite side from which the wheels are used for row cleaners.

Left and Right is reference from behind the machine facing the direction of travel.

RIGHT HAND 4 HOLE WHEEL

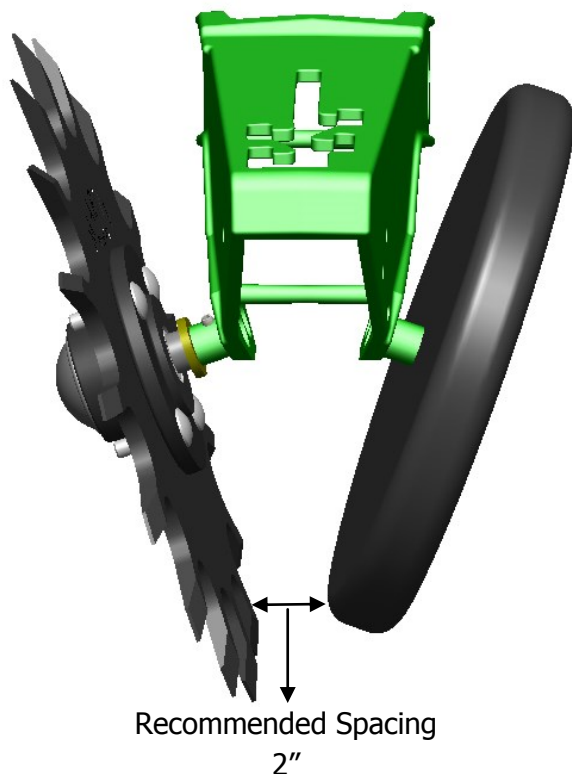
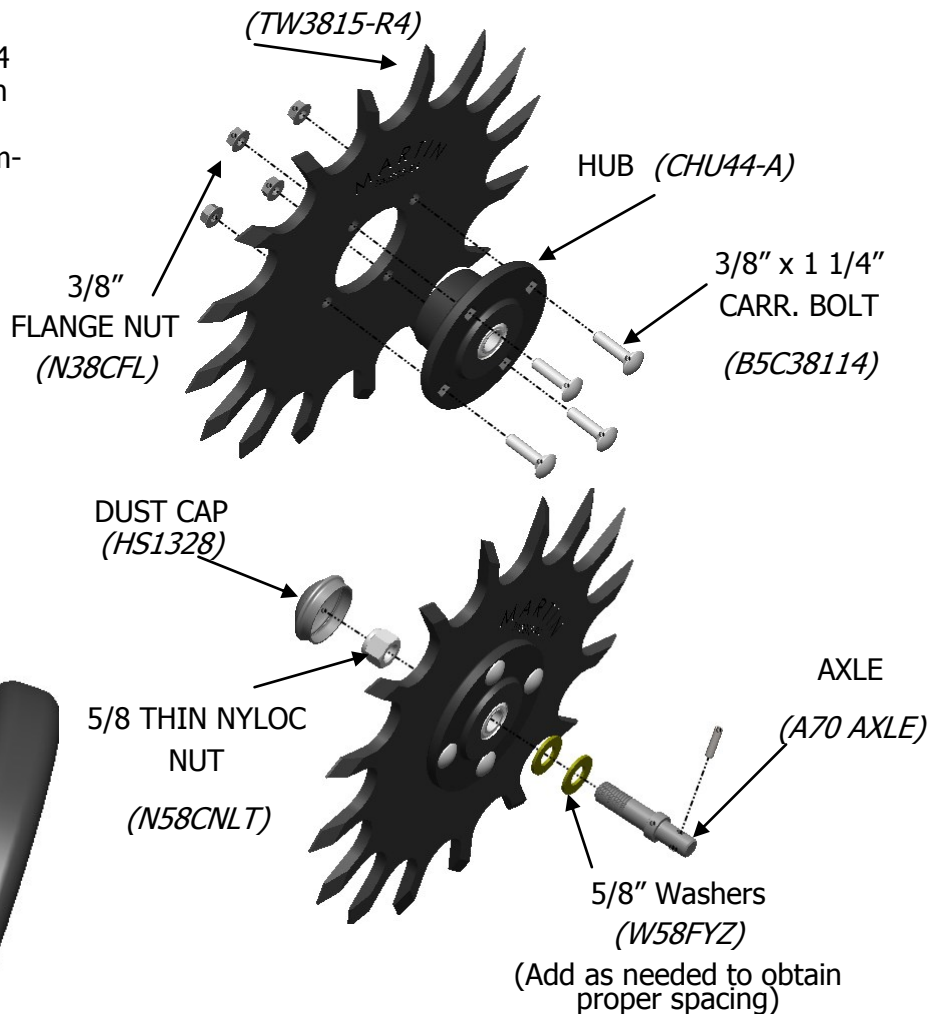

Hardware Required Per Wheel

1) CHU44-A Hub	Qty 1
2) A70 Axle	Qty 1
3) 5/8" Flat Washer	Qty 4
4) 5/8" Thin Nyloc Nut	Qty 1
5) 3/8" x 1 1/4" Carriage Bolt	Qty 4
6) 3/8" Flange Nut	Qty 4
7) HS1328	Qty 1