

# ***BSCW156D***

## **20 Point Dimple Closing Wheel for Deere 60 Series Drill**

### **Installation Instructions**

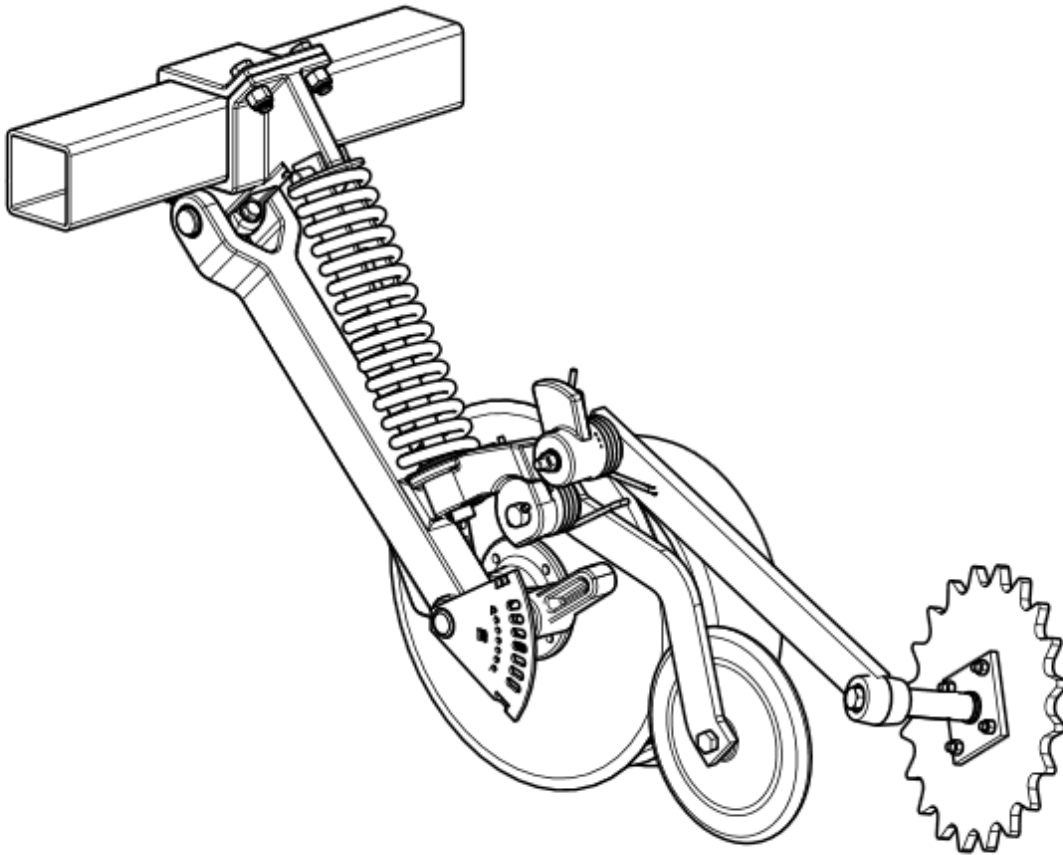

### **Martin Planter Attachments**

**Martin Industries LLC**

206 Elk Fork Road

Elkton, KY 42220

Telephone: 270-265-5817

E-Mail: [martin@martintill.com](mailto:martin@martintill.com)

[www.martintill.com](http://www.martintill.com)



## INSTRUCTIONS FOR BSCW-156D ASSEMBLY

- 1) Place the 156-41 Mounting Plate up to the DW2013-4 Wheel.
- 2) Insert the four 3/8" x 1 1/4" bolts through the hole and thread on the 3/8" flange nuts then tighten.

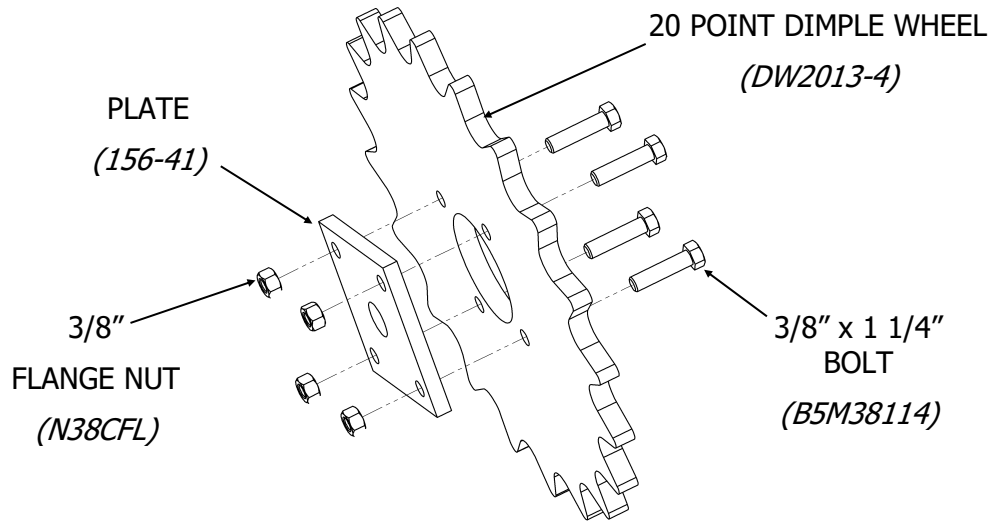

## INSTRUCTIONS FOR ASSEMBLING THE BSCW-156D TO THE GRAIN DRILL

- 1) Add spacers to the small end of the 156-2 Shaft (**Note: The spacers are for adjustment. They can be applied to either side of the 156-41 Mounting Plate.**)
- 2) Insert the 156-2 Shaft thru the hole in the 156-41 Mounting Plate.
- 3) Insert the 5/8" x 7 1/2" bolt thru the bearing in the Grain Drill.
- 4) Slide the SCW156 Wheel Assembly onto the 5/8" x 7 1/2" Bolt.
- 5) Thread on the 5/8" Lock Nut and tighten.

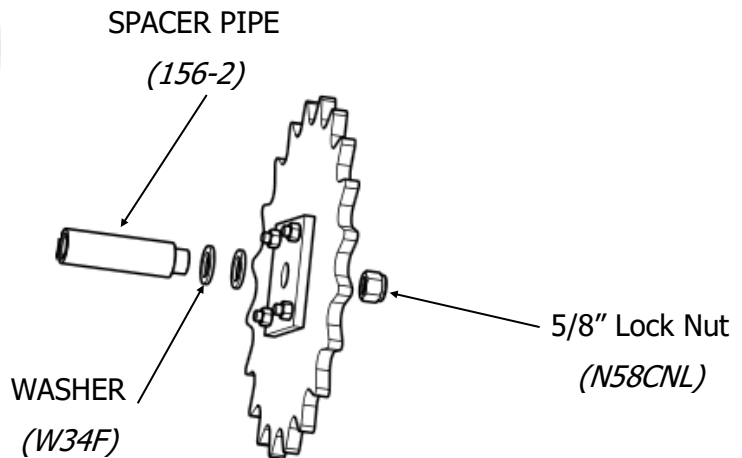
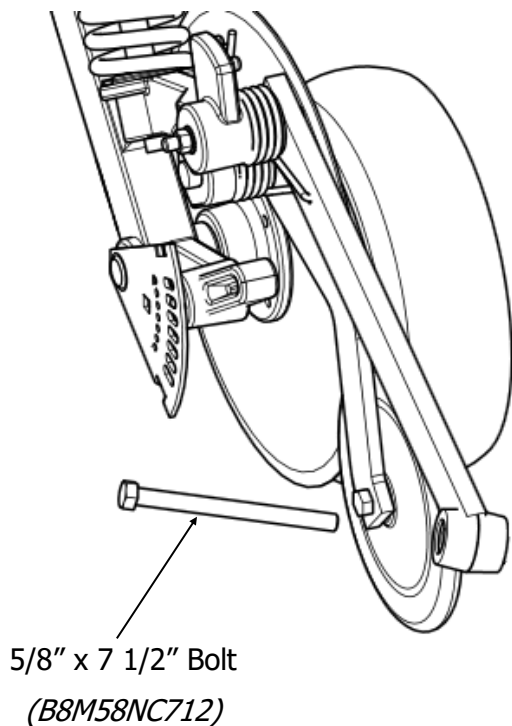

### Hardware Required Per Wheel

- |                       |       |
|-----------------------|-------|
| 1) 3/8" X 1 1/4" Bolt | Qty 4 |
| 2) 3/8" Flange Nut    | Qty 4 |
| 3) 5/8" x 7 1/2" Bolt | Qty 1 |
| 4) 5/8" Lock Nut      | Qty 1 |
| 5) Spacer             | Qty 2 |