



UMO 150

UNIT MOUNTED OPENER- LIQUID FERTILIZER

BOLT ON GUARD INSTALLATION (900294/295)

Installing Bolt-on Guard to Prevent Residue build up between blade and beam

STEP 1): Remove 3 x 5/16-18 X 1 1/4" Bolts and Nuts from Umo Beam as shown below.

Remove UMO Shoe Stop Bracket (900175/900176).

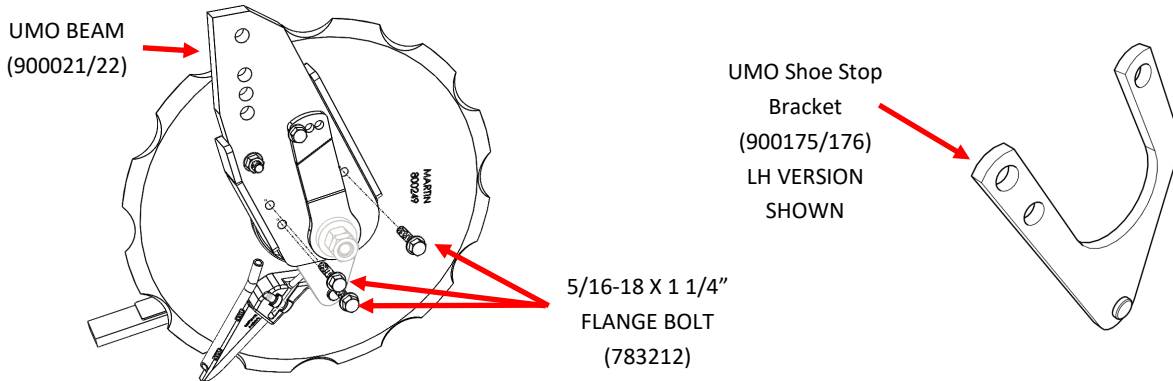

STEP 2): Slide on Guard Assembly as shown below to the inside where the original stop bracket was located . Slide up so that the guard wrap makes contact with bottom of shoe.

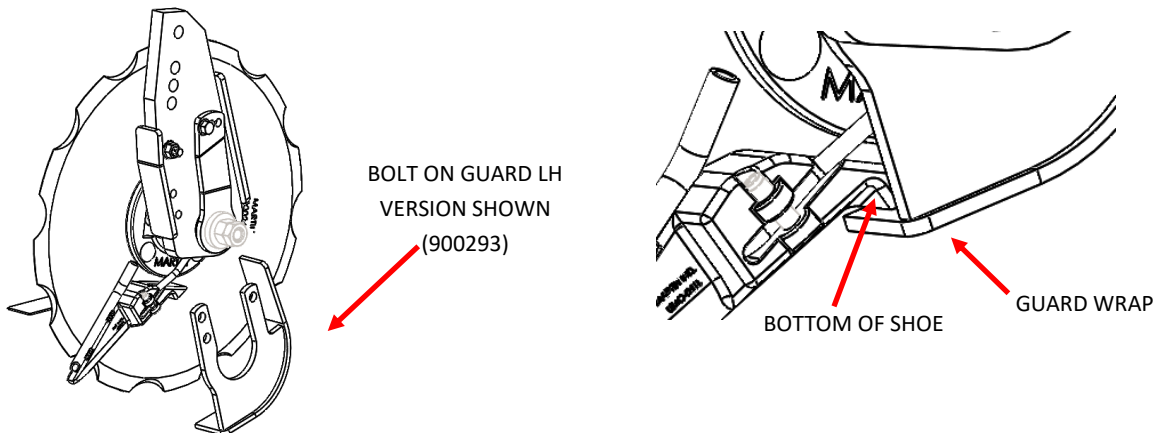

STEP 3): Install the Guard with 3 new 5/16-18 X 1 1/4 bolts and new Flange Nuts included with kit.

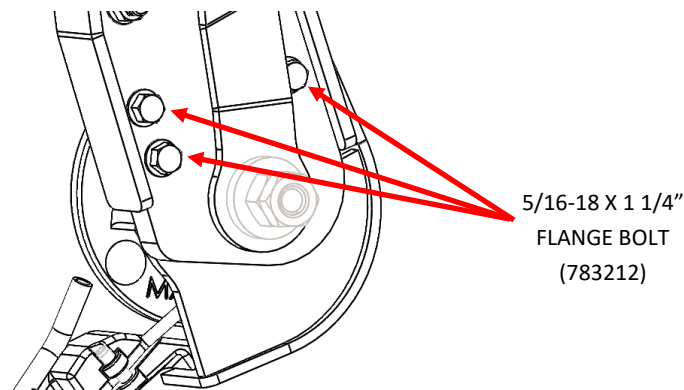

4-28-2020